



Eddy Current Probes & Accessories

Waygate Technologies – leaders in eddy current NDT

For more than 30 years, Waygate Technologies has been recognized internationally for our high-quality eddy current instruments and accessories. Carrying the legacy of Hocking NDT, our products are among the world's most advanced for the detection of cracks and flaws, both during and after production processes. Wherever metals are used, you can turn to the specialist knowledge of Waygate Technologies for our cost-effective, innovative design and manufacturing solutions.

Why eddy current?

Eddy current is a fast, accurate and cost-effective electro-magnetic non-destructive testing method for the detection of surface or near-surface flaws as well as heat treatment verification. Its uses range from the inspection of raw materials to quality control of finished products to maintenance inspections.

Additional advantages of eddy current inspections include:

- Highly accurate and repeatable flaw detection
- High inspection speeds with low surface preparation
- Flaw detection through coatings, such as paint
- Good discrimination between flaw types with no couplant, consumables or radiation hazards

Why Waygate Technologies?

We provide full eddy current solutions, from hand-held devices to probes for standard and special applications. Designed to meet industry's most stringent standards, our solutions are registered to the highest international quality standard ISO9001.

Eddy current applications

Waygate Technologies has the knowledge and expertise to meet your inspection needs, whether your product is a critical jet engine component, part of an offshore platform, a tube in a power station or simply raw metal on the production line. Our efficient and reliable inspection equipment adheres to stringent requirements in applications ranging from aerospace research to steel production.

Aerospace

Our instruments are used to carry out a vast range of procedures for aircraft inspection. Checks are made to detect flaws in wings, wheels, engines, bodies, gears, rotors and many other parts, providing the inspections you need when in-service safety is absolutely critical.

Engineering structures

Assessing the integrity of structures such as oil rigs, bridges, ships, cranes and heat exchangers, Waygate Technologies can bring higher levels of quality and reliability to all aspects of heavy engineering.

Metals industry

Eddy current instruments are used daily by the metals industry to inspect rods and bars, ERW pipe, seamless pipe and extruded sections for the identification of cracks, splits, and lack of fusion. They also are used to identify alloys, sort metals and measure the density of powder metal parts.

Contents

Ordering eddy current probes	4
Choosing a probe	4
Sensor formats	4
Eddy current reference	6
Standard depth of penetration	6
Shielded surface probes 1	8
Shielded surface probes 2	11
Adjustable copper absolute shielded pencil probes	13
Unshielded surface probes	14
Absolute unshielded broadband probes	14
Absolute unshielded probes	15
Electrical conductivity	16
Electrical conductivity probes	16
Operating reference blocks	17
Correction factor for round parts	18
Conductivity of common materials	18
Aircraft fastener inspection 1	19
Low frequency ring (donut) probes	19
Spot face probes	20
Aircraft fastener inspection 2	21
Sliding probes, dual element	21
Bolt hole inspection	22
Rigid bolt hole probes	23
Rotational probes	26
Weld inspection	27
WeldScan	27
Encircling probes	28
Industrial applications 1	29
Flat surface probes	29
Industrial applications 2	30
Static differential scanning probes	30
Eddy current kits	31
Cables	33
Adapters and test blocks	34

Ordering eddy current probes

Choosing a probe

1. Identify which instrument you wish to use the probe with.
2. Identify which frequency you wish to inspect at.
3. Decide whether you require an absolute or differential probe.
4. Define the probe geometry – access to the appropriate area to be inspected will often determine the shape and size necessary.
5. Decide if the probe needs to be shielded.

Frequency

Eddy current probes operate over a band of frequencies. This depends on the probe and the instrument with which they are being used. Frequencies marked on the probe indicate the setting for best performance.

Best performance on impedance plane instruments used in bridge mode is generally achieved at a frequency (f) at which the probe's impedance (Z_p) has a similar value to the instrument bridge impedance (Z_I). The Mentor EM is 50 Ohms.

Probe inductances (L) are given in the tables to enable Z_p to be calculated for any frequency (f). $Z_p = 2\pi fL$ ohms. In most cases the winding resistance has little effect and can be ignored.

High frequency probes are appropriate for surface crack detection.

Low frequencies are appropriate for penetration of non-ferrous materials, e.g. for the detection of the sub-surface cracks or corrosion. Lower frequency allows greater penetration. Low frequency probes tend to be larger than high frequency probes. Low frequency probes are not as sensitive to short shallow cracks as they create a larger eddy current field.

Sensor formats

Absolute

Probes consisting of a single coil (or winding) interrogating the test piece which respond to all changes in material, heat treatment, shape, etc. Changes of a gradual nature are detected, as well as sharp discontinuities.



Differential

Probes with two or more balanced windings generally in the same are of the test piece. Designed to respond selectively to sharp changes in the test piece, e.g. cracks, they are insensitive to slow changes of material or geometry and long continuous defects. In the case of the encircling coils used for material sorting or comparison purposes the coils are separated with one loaded with an .unknown. part while the other has the 'unknown' part placed in it.

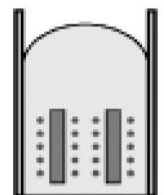

Reflection

Probes in which a sense coil/s (pick-up/s) near the test piece detects the eddy current field reflected from it. The eddy currents are created by a driver coil situated around or near the pick-up coil(s). These probes are usually differential, but can be absolute, with a balance coil situated remote from the test piece also surrounded by, or adjacent to, a similar driver coil to ensure an accurate balance. Their principle advantage is a wide frequency band and a good signal to noise ratio.

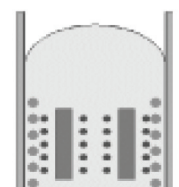

Ordering eddy current probes

Unshielded

These probes are lower in cost and produce a broader eddy current field than shielded probes. They are more tolerant of lift-off and probe angle changes and require less passes to scan an area due to their broad field. This is a benefit when only larger cracks are of interest and where the inspection area is uniform.

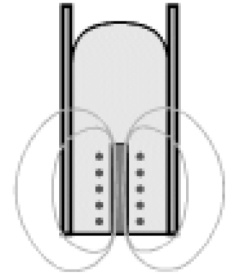

Shielded

The sideways spread of the eddy current field is restricted by placing shielding around the sensor. This focuses the field into a narrow beam at the end of the sensor. It is thus more sensitive to short cracks, unaffected by edges, geometry changes, adjacent ferrous materials and can operate close to edges. This narrow field means that closer scans are required to cover a given area.

Shielded probes should always be considered for work on or near edges, angles, etc. or for inspecting non-ferrous materials adjacent to ferrous materials, e.g. wing skins around and near ferrous fasteners..

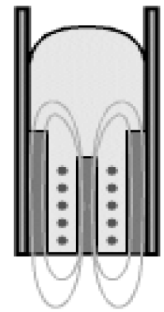

Dimensions

The dimensions may be rounded for convenience or brevity. In those cases where a particular dimension is important an accurate figure or drawing can be supplied on request. The drawings in these documents are not necessarily to scale.

Waygate Technologies pursues a policy of continuous product development and improvement, specifications are therefore, liable to change without notice.

If you have any questions about the range of Waygate Technologies eddy current probes and accessories, or you would like to place an order, please contact your local Waygate Technologies representative. If you would like to discuss your special probe requirements in more detail, please contact us directly.

Eddy current reference

Standard depth of penetration

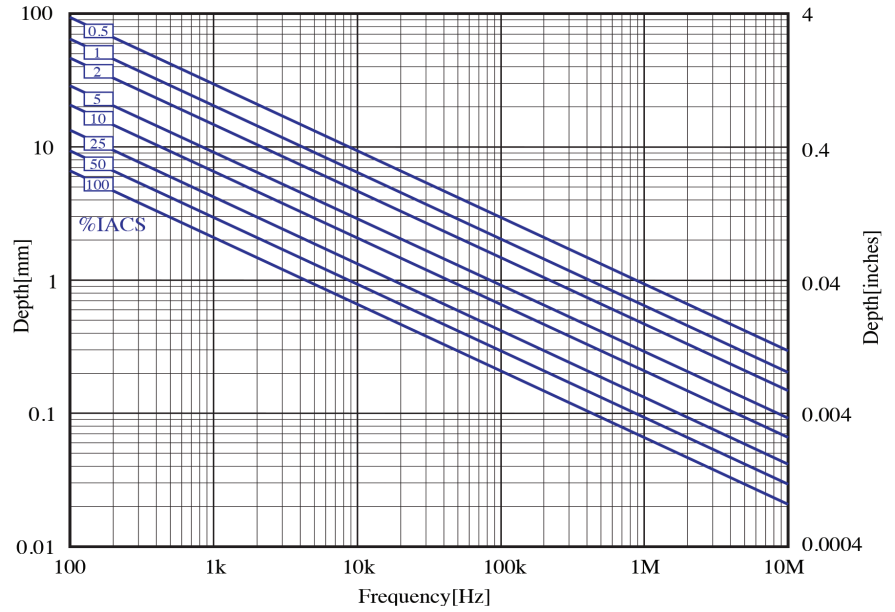
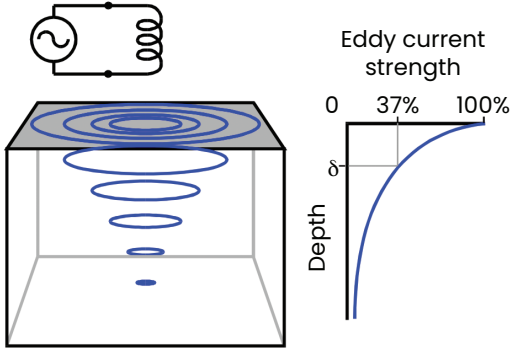

The standard depth of penetration is defined as that depth at which the eddy current strength has dropped to 37% of that at the surface. For this table the Relative Permeability has been assumed as 1.

Using IACS

$$\delta = \sqrt{\frac{431,000}{\sigma \mu r f}} \quad f = \frac{431,000}{\delta^2 \mu r \sigma}$$

Using MSm⁻¹

$$\delta = \sqrt{\frac{250,000}{\sigma \mu r f}} \quad f = \frac{250,000}{\delta^2 \mu r \sigma}$$

f = Frequency (Hz)
 σ = Conductivity
 μr = Relative permeability
 δ = Standard depth of penetration (mm)

Eddy current reference

SI units

Quantity	Symbol	Unit	Symbol
Electric	I	ampere	A
Current density	J		Am^{-2}
Electric charge	Q	coulomb	C
Electric flux density d			Cm^{-2}
Capacitance	C	farad	F
Inductance	L, M	henry	H
Permeability	μ		Hm^{-1}
Frequency	f	hertz	Hz
Length	l	metre	m
Conductance	G	Siemens	S
Conductivity	σ		Sm^{-1}
Magnetic flux density	B	tesla	T
Electric potential	V	volt	V
Magnetic flux	ϕ	weber	Wb
Impedance	Z	ohm	Ω
Reactance	Ξ	ohm	Ω
Resistance	P	ohm	Ω

Conversion factors

To Convert	Multiply by;
Inches to cm	2.54
cm to inches	0.3937
%IACS to MSiemens m^{-1}	0.58
MSiemens m^{-1} to %IACS	1.724

Shielded surface probes 1

Application

Absolute probes for general purpose inspection.

Features

Double shielded probes with a stainless steel shaft, a choice of normal, cranked or 90° tip. Supplied with a microdot connector.

Shielded straight pencil probe with Delrin handle				
D	20kHz-200kHz	50kHz-500kHz	350kHz-3MHz	2MHz-10MHz
	Fe and NFe	Fe and NFe	NFe	NFe
4.45	610-034-XXX	610-035-XXX	610-037-XXX	610-039-XXX
3.2	610-044-XXX	610-045-XXX	610-047-XXX	
2.3	613-034-XXX	613-035-XXX		
Inductance (μH)	120	47	8.2	1.3

Available lengths	
L *	-XXX
114	-002
152	-003
203	-004
254	-005
305	-006

Note: lookup table for required length and drop height inputs to replace "-XXX" value

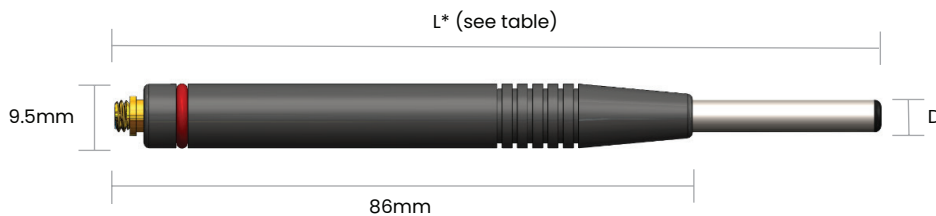

Shielded straight pencil probe with metal handle				
D	20kHz-200kHz	50kHz-500kHz	350kHz-3MHz	2MHz-10MHz
	Fe and NFe	Fe and NFe	NFe	NFe
4.45	611-034-XXX	611-035-XXX	611-037-XXX	611-039-XXX
3.2	611-044-XXX	611-045-XXX	611-047-XXX	
2.3	611-034-XXX	611-035-XXX		
Inductance (μH)	120	47	8.2	1.3

Available lengths	
L *	-XXX
38	-000
76	-001
114	-002
152	-003
203	-004
254	-005

Note: lookup table for required length and drop height inputs to replace "-XXX" value

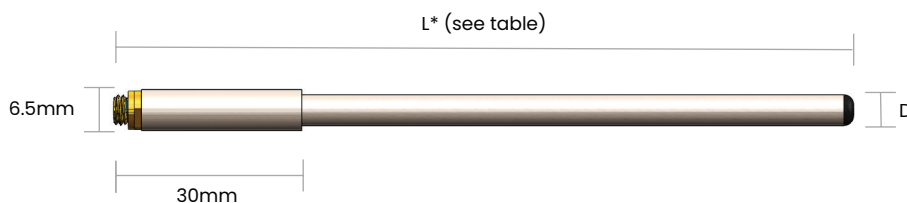

inches	1/32	.004	1/16	0.08	1/8	1/5	1/4	3/8	0.4	1/2	5/8	3/4	1	1 1/2	2	3	4	5	6	7	8	9	10	11	12
mm	0.8	1	1.6	2	3.2	5	6.4	9.5	10	12.7	15.9	19	25.4	38	51	76	102	127	152	178	203	229	254	279	305

Shielded surface probes 1

90° tip pencil probe with metal handle					Length (L)		
D	20kHz-200kHz	50kHz-500kHz	350kHz-3MHz	2MHz-10MHz	Drop height (DH)	51	76
	Fe and Nfe	Fe and Nfe	Nfe	Nfe	Min		
4.45	611-074-XXX	611-075-XXX	611-077-XXX	611-079-XXX	6	-000	-001
3.2	611-084-XXX	611-085-XXX	611-087-XXX		13	-012	-013
2.3	614-074-XXX	614-075-XXX			19	-018	-019
Inductance (μH)	120	47	8.2	1.3	25	-024	-025

Note: lookup table for required length and drop height inputs to replace "-XXX" value

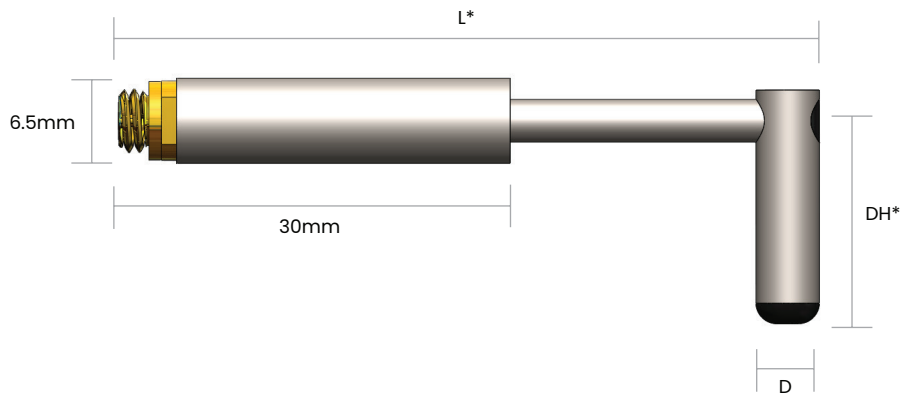
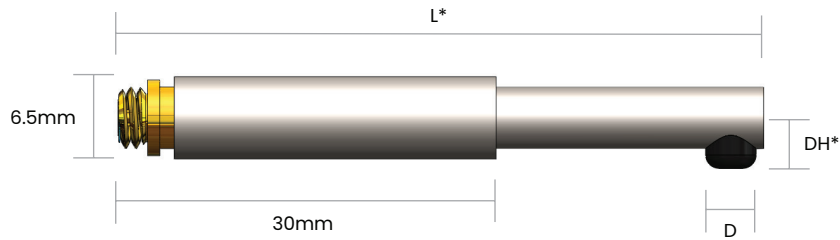

inches	1/32	.004	1/16	0.08	1/8	1/5	1/4	3/8	0.4	1/2	5/8	3/4	1	1 1/2	2	3	4	5	6	7	8	9	10	11	12
mm	0.8	1	1.6	2	3.2	5	6.4	9.5	10	12.7	15.9	19	25.4	38	51	76	102	127	152	178	203	229	254	279	305

Shielded surface probes 1

90° tip pencil probe with Delrin handle				
D	20kHz-200kHz	50kHz-500kHz	350kHz-3MHz	2MHz-10MHz
	Fe and Nfe	Fe and Nfe	Nfe	Nfe
4.45	610-074-XXX	610-075-XXX	610-077-XXX	610-079-XXX
3.2	610-084-XXX	610-085-XXX	610-087-XXX	
2.3	613-074-XXX	613-075-XXX		
Inductance (μH)	120	47	8.2	1.3

Drop height (DH)	Length (L)			
	114	152	203	254
Min	-002	-003	-004	-005
6	-008	-009	-010	-011
13	-014	-015	-016	-017
19	-020	-021	-022	-023
25	-026	-027	-028	-029

Note: look up table for required length and drop height inputs to replace “-XXX” value

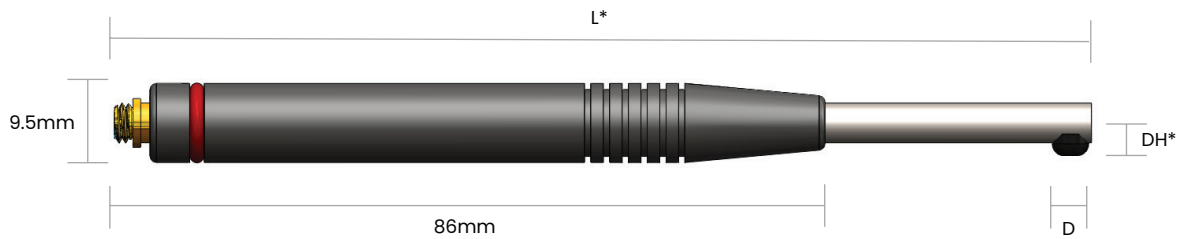
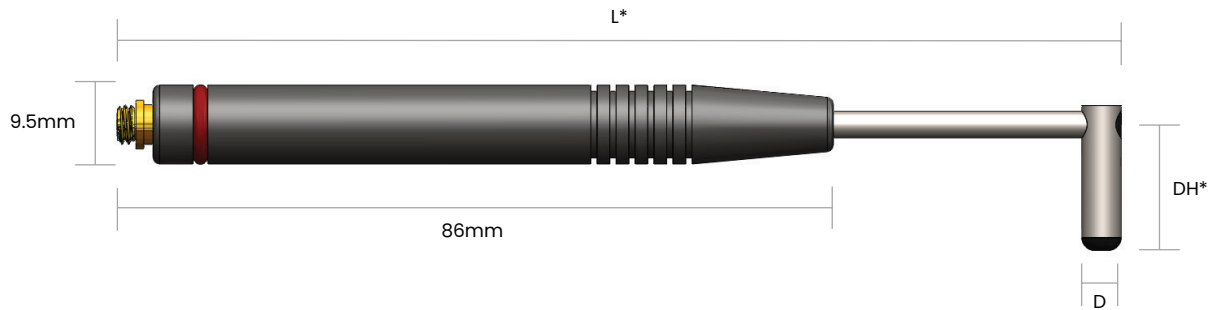

inches	1/32	.004	1/16	0.08	1/8	1/5	1/4	3/8	0.4"	1/2	5/8	3/4	1	1 1/2	2	3	4	5	6	7	8	9	10	11	12
mm	0.8	1	1.6	2	3.2	5	6.4	9.5	10	12.7	15.9	19	25.4	38	51	76	102	127	152	178	203	229	254	279	305

Shielded surface probes 2

Application

Absolute probes for general purpose inspection.

Features

Double shielded probes with a stainless steel shaft. Available with a 45° crank or a 15° crank with a 90° tip. Microdot connector.

45° cranked pencil probe with metal handle					Available length (L)	
D	20kHz-200kHz	50kHz-500kHz	350kHz-3MHz	2MHz-10MHz	L *	XXX
	Fe and Nfe	Fe and Nfe	Nfe	Nfe		
4.45	611-074-XXX	611-075-XXX	611-077-XXX	611-079-XXX	76	-075
3.2	611-084-XXX	611-085-XXX	611-087-XXX		114	-076
2.3	614-074-XXX	614-075-XXX			152	-077
Inductance (μH)	120	47	8.2	1.3	203	-078
					254	-079

Note: lookup table for required length input to replace "-XXX" value



45° cranked pencil probe with Delrin handle					Available length (L)	
D	20kHz-200kHz	50kHz-500kHz	350kHz-3MHz	2MHz-10MHz	L *	XXX
	Fe and Nfe	Fe and Nfe	Nfe	Nfe		
4.45	610-054-XXX	610-055-XXX	610-057-XXX	610-059-XXX	114	-076
3.2	610-064-XXX	610-065-XXX	610-067-XXX		152	-077
2.3	613-054-XXX	613-055-XXX			203	-078
Inductance (μH)	120	47	8.2	1.3	254	-079
					305	-080

Note: lookup table for required length input to replace "-XXX" value

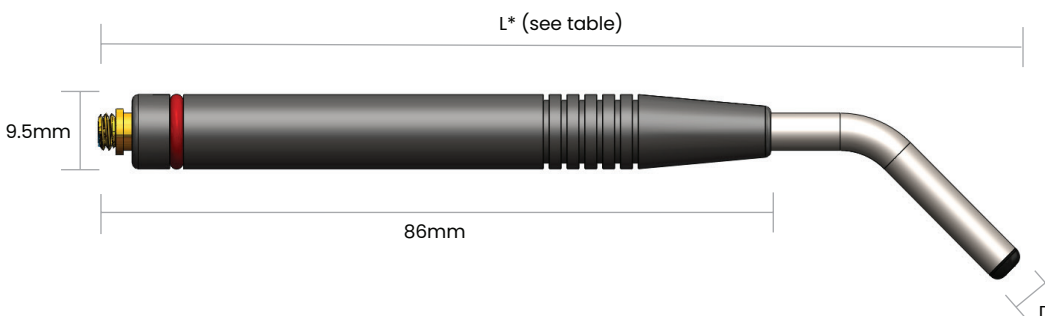

Shielded surface probes 2

15° cranked pencil probes with 90° tip and Delrin handle

D	20kHz-200kHz	50kHz-500kHz	350kHz-3MHz	2MHz-10MHz
	Fe and Nfe	Fe and Nfe	Nfe	Nfe
4.45	610-094-XXX	610-095-XXX	610-097-XXX	610-099-XXX
3.2	610-104-XXX	610-105-XXX	610-107-XXX	
2.3	613-094XXX	613-095-XXX		
Inductance (μH)	120	47	8.2	1.3

Drop height (DH)	Length (L)		
	114	152	203
Min	-031	-042	-043
6.4	-111	-122	-123
12.7	-171	-182	-183
19	-231	-242	-243
25.4	-291	-302	-303

Notes:

- 1) Lookup table for required length and drop height inputs to replace "-XXX" value
- 2) If length (L) is greater than 114mm then crank length (CL) = 25mm otherwise CL is 15mm

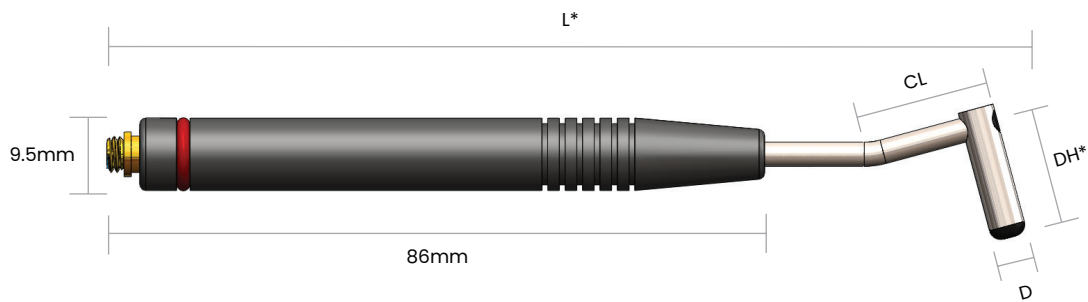

15° cranked pencil probes with 90° tip and metal handle

D	20kHz-200kHz	50kHz-500kHz	350kHz-3MHz	2MHz-10MHz
	Fe and Nfe	Fe and Nfe	Nfe	Nfe
4.45	611-094-XXX	611-095-XXX	611-097-XXX	611-099-XXX
3.2	611-104-XXX	611-105-XXX	611-107-XXX	
2.3	614-094XXX	614-095-XXX		
Inductance (μH)	120	47	8.2	1.3

Drop height (DH)	Length (L)				
	51	76	114	152	203
Min	-000	-001	-002	-003	-004
6.4	-006	-007	-008	-009	-010
12.7	-012	-013	-014	-015	-016
19	-018	-019	-020	-021	-022
25.4	-024	-025	-026	-027	-028

Notes:

- 1) Lookup table for required length and drop height inputs to replace "-XXX" value
- 2) If length (L) is greater than 114mm then crank length (CL) = 25mm otherwise CL is 15mm

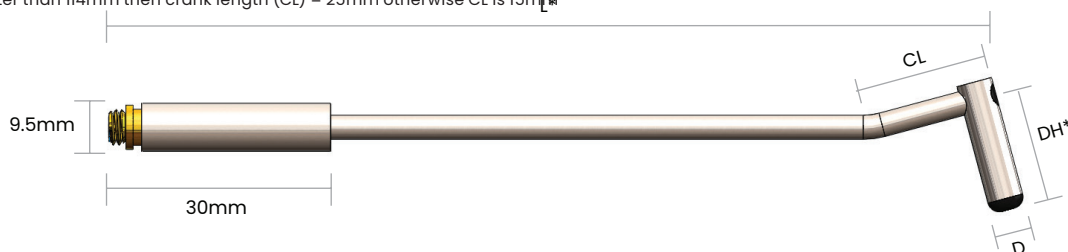

Adjustable copper absolute shielded pencil probes

Application

Absolute probes for general purpose inspection in locations with complex geometry.

Features

Double shielded probes, with a microdot connection and a copper shaft that can be manipulated into the required shape for inspection. Can also be provided with a 90 degree tip on request.

Adjustable copper absolute shielded pencil probes						
L	20kHz-200kHz		50kHz-500kHz		350kHz-3MHz	
100	615-037-002	(104P8C)	615-037-003	(105P8C)	615-037-004	(106P8C)
Inductance (μH)	120		47		8.2	

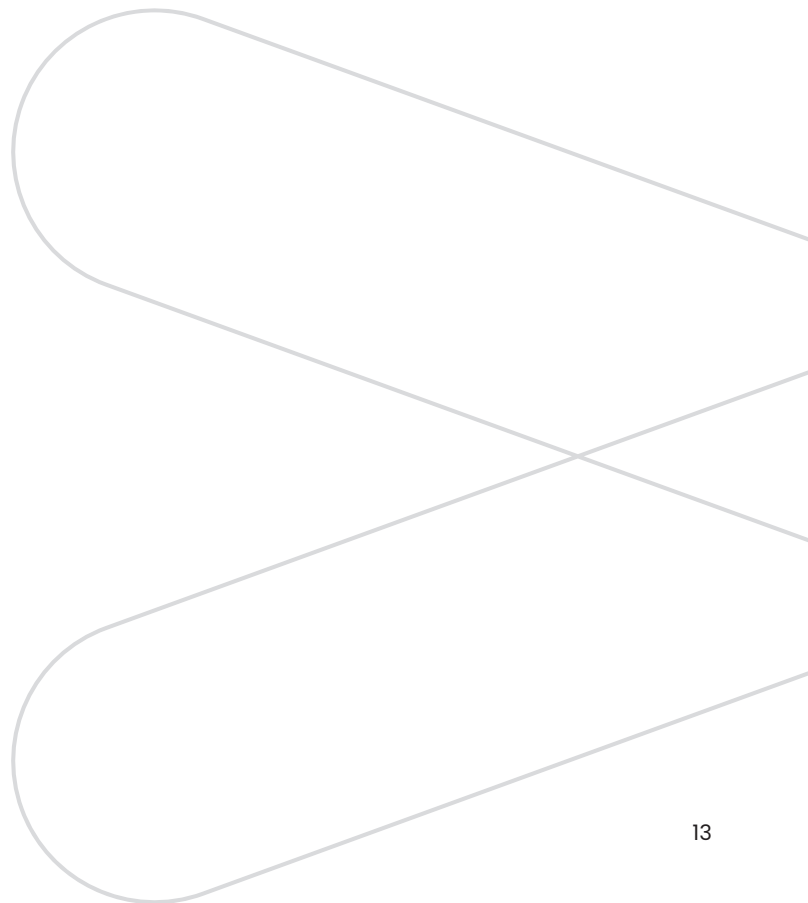

Unshielded surface probes

Absolute unshielded broadband probes

Application

This is a range of absolute heavy duty probes for general industrial use.

Features

All probes are made from Ultem, fitted with BNC connector and employ an absolute style coil. The range extends from high to relatively low frequencies, optimised for each frequency range.

Absolute unshielded broadband probe										
L	2kHz-15kHz		7kHz-60kHz		35kHz-250kHz		2MHz-10MHz		500kHz-4MHz	
	632-132-000	(130P5U)	632-133-000	(130P4U)	632-134-000	(130P3U)	632-136-000	(130P2U)	632-137-000	(130P1U)
Inductance (μH)	1500 $\mu\text{H} \pm 75.0\mu\text{H}$		390 $\mu\text{H} \pm 20.0\mu\text{H}$		82 $\mu\text{H} \pm 5.0\mu\text{H}$		22 $\mu\text{H} \pm 2.0\mu\text{H}$		5.6 $\mu\text{H} \pm 0.5\mu\text{H}$	

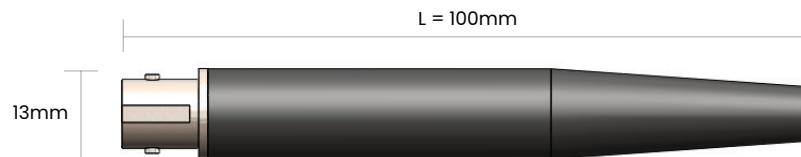

Absolute unshielded probes

Application

Absolute unshielded surface probes are broad field probes which are most effective when used away from edges and sharp changes in geometry. Used extensively in the Aerospace Industry

Features

All probes are made from Ultem, fitted with a Microdot connector and employ an absolute style coil.

Unshielded straight pencil probe with Delrin handle

L	20kHz-200kHz		50kHz-500kHz		350kHz-3MHz		2MHz-10MHz	
100	610-014-000	(120PIA)	610-015-000	(121PIA)	610-017-000	(122PIA)	610-018-000	(124PIA)
Inductance (μH)	120		47		8.2		1.3	

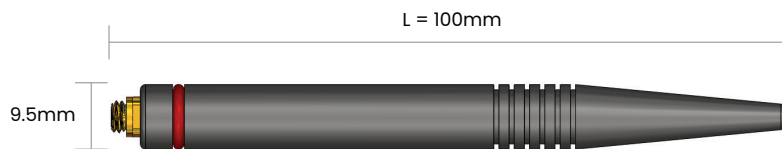

Knife edged absolute unshielded probes

L	20kHz-200kHz		50kHz-500kHz		350kHz-3MHz		2MHz-10MHz	
135	610-024-000	(350PIA)	610-025-000	(351PIA)	610-027-000	(353PIA)	610-028-000	(354PIA)
Inductance (μH)	120		47		8.2		1.3	

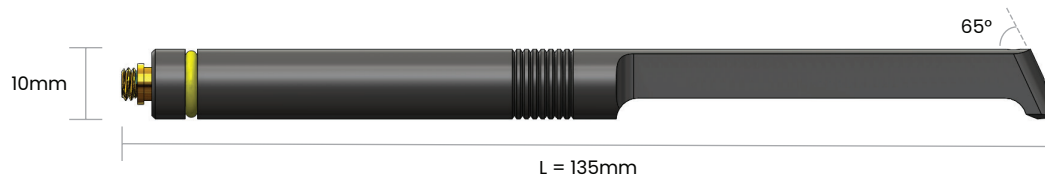

Electrical conductivity

Electrical conductivity probes

Application

Electrical conductivity measurement of non-ferrous metals. Alloy identification and verification, the verification of heat treatment during manufacture and to detect in-service heat damage, detection of changes in material grade, for metal sorting and to determine the density of powder metal parts.

Features

For operation with Waygate Technologies Mentor EM, AutoSigma 3000, Phasec instruments. Mentor conductivity probe are supplied with a Lemo 7P connector while Autosigma/Phasec are provided with a Lemo 5P.

Conductivity probes						
GE IT #		Frequency	Style	D (mm)	L1 (mm)	L2 (mm)
Used only on the Autosigma and Phasec (60kHz)						
632-745-000	(47P001)	60kHz and 500kHz	Straight	12.7	58	-
632-746-000	(47P002)	500kHz	Straight	7.87	58	-
632-745-002		60kHz and 500kHz	90°	12.7	33	67
632-746-002		500kHz	90°	7.87	33	67
Used only on the Mentor EM instrument						
632-745-001		60kHz and 500kHz	Straight	12.7	82	-
632-746-001		60kHz and 500kHz	Straight	7.87	82	-
632-745-003		60kHz and 500kHz	90°	12.7	35	71
632-746-003		60kHz and 500kHz	90°	7.87	35	71
Cables						
640-010-010	Autosigma 3000/Phasec					
640-010-315	Mentor					

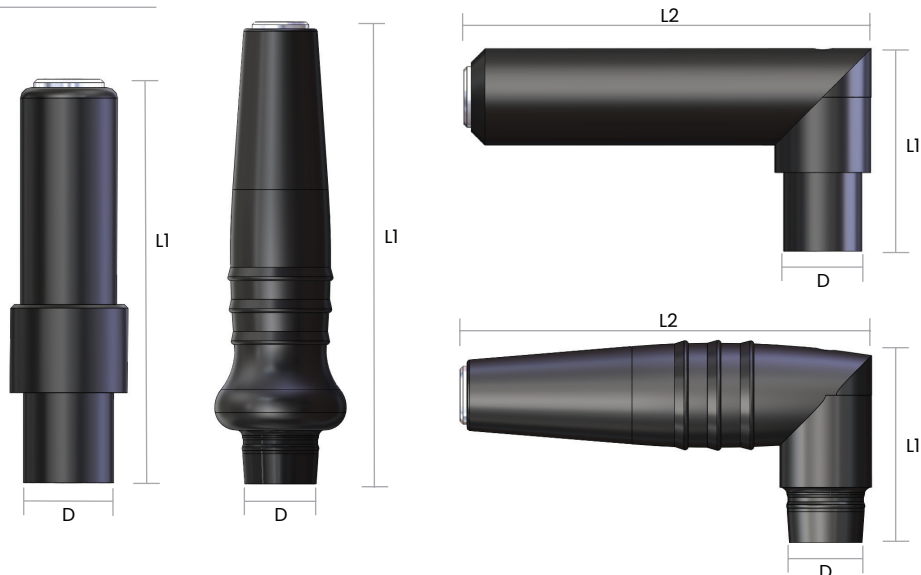

Operating reference blocks

Conductivities

Nominal values. Precise values will be shown on the blocks.

Part number		IACS%	M Sm^{-1}	Material	Description
078-540-020	(47A011)	1	0.6	Ti 2TA7	Single conductivity ref block
078-540-021	(47A012)	2	1.2	Stainless steel 303S	Single conductivity ref block
078-540-022	(47A013)	9	5.2	Nickel silver LC1291	Single conductivity ref block
078-540-023	(47A014)	19.5	11	Phosor bronze	Single conductivity ref block
078-540-024	(47A015)	24	14	Brass LM5681	Single conductivity ref block
078-540-025	(47A016)	28	16	Al 5083	Single conductivity ref block
078-540-026	(47A017)	33	19	Al 7075-TF	Single conductivity ref block
078-540-027	(47A018)	43	25	Al 6061-TF	Single conductivity ref block
078-540-028	(47A019)	47	27	Al 6082-TF	Single conductivity ref block
078-540-029	(47A020)	60	35	Al 1200-H4	Single conductivity ref block
078-540-030	(47A021)	89	52	CuCr/CuZr LC639	Single conductivity ref block
078-540-031	(47A022)	100	58	Cu	Single conductivity ref block
078-540-043	(47A024)	38	22	Al 2014A-TG	Single conductivity ref block
078-540-017	(47A023)	9 and 58	5 and 34	Ni/AG and Al	Dual ref conductivity block
640-020-033	(47A010)	-	-	-	Conductivity holder - 5 blocks
640-020-032	(47A025)	-	-	-	Conductivity holder - 3 blocks

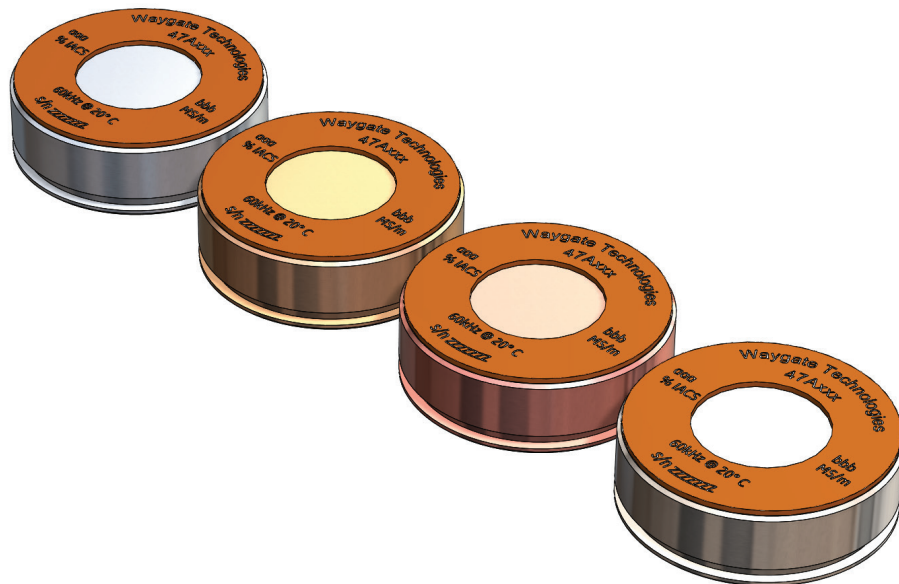

Correction factor for round parts

Conductivity correction factors for round aluminium alloy bars and tubes.

For use with the Waygate Technologies AutoSigma 3000.

Test piece diameter	Factor for 47P001		Factor for 47P002
	At 500kHz	At 60kHz	At 500kHz
6.4	–	–	0.792
9.5	0.756	0.773	0.882
12.7	0.837	0.841	0.927
19	0.902	0.904	0.957
25.4	0.933	0.933	0.972
38	0.960	0.960	0.981
51	0.972	0.970	0.987
63.5	0.978	0.975	0.991
76	0.980	0.979	0.992
89	0.984	0.984	0.993
102	0.985	0.986	0.995
127	0.989	0.992	0.996

AutoSigma 3000 reading ÷ factor = corrected value

Full tables are available from Waygate Technologies on request.

Minimum test piece thickness for aluminium alloys	
Frequency	Min. test piece thickness
60kHz	1.5mm
500kHz	0.5mm

Conductivity of common materials

	IACS	MSm ⁻¹
Silver (pure)	107	62
Copper annealed	100	58
Gold	78	45
Aluminium (pure)	65	38
Brass (Cu-Zn) 5% Zn	55	32
Aluminium alloys	25-60	15-35
Magnesium	39	23
Brass (Cu-Zn) 15% Zn	37	21
Molybdenum	33	19
Al 7075-76	32	18.5
Tungsten	32	18.5
Al 2024-74	30	17.5
Zinc	29	17
Brass (Cu-Zn) 30% Zn	28	16
Brass + lead	12-25	7-14.5
Magnesium bronze	24	14
Beryllium copper	24	14
Cu/Ni (90/10)	12	7
Lead	8	4.5
Cu/Ni (70/30)	5	3
Zirconium	4	2.5
Stainless steel	2.5	1.5
Titanium	1-4	0.5-2.5
Inconel 600	1	0.58

%IACS = MSiemens m⁻¹ x 0.58

MSiemens m⁻¹ = % IACS x 1.724

Aircraft fastener inspection 1

Low frequency ring (donut) probes

Application

To detect surface and sub-surface flaws around aircraft fastener holes without removal of the fastener. These absolute reflection probes will penetrate several layers of non-ferrous material with good sensitivity.

Features

Absolute - reflection probes provided with a 4 pin lemo connector compatible with most phase plane instruments. These lower frequencies probes achieve greater penetration into inspection material.

Ring (donut) probes					
Frequency	D1	D2	D3	Part number	
250Hz-40kHz	5	16	24	632-501-050	(702P05A)
500Hz-40kHz	6	15	24	632-501-060	(702P06A)
500Hz-40kHz	6	19	28	632-501-061	(702P06B)
250Hz-40kHz	8	22	30	632-501-080	(702P08A)
250Hz-40kHz	10	22	30	632-501-100	(702P10A)
80Hz-50kHz	13	29	37	632-501-130	(702P13A)
80Hz-50kHz	13	32	40	632-501-131	(702P13B)
80Hz-50kHz	14	29	37	632-501-140	(702P14A)
80Hz-50kHz	15	31	39	632-501-150	(702P15A)
80Hz-50kHz	16	29	37	632-501-160	(702P16A)
80Hz-50kHz	16	40	48	632-501-161	(702P16B)
80Hz-50kHz	20	38	46	632-501-200	(702P20A)
80Hz-50kHz	25	41	49	632-501-250	(702P25A)
80Hz-50kHz	28	44	52	632-501-280	(702P28A)

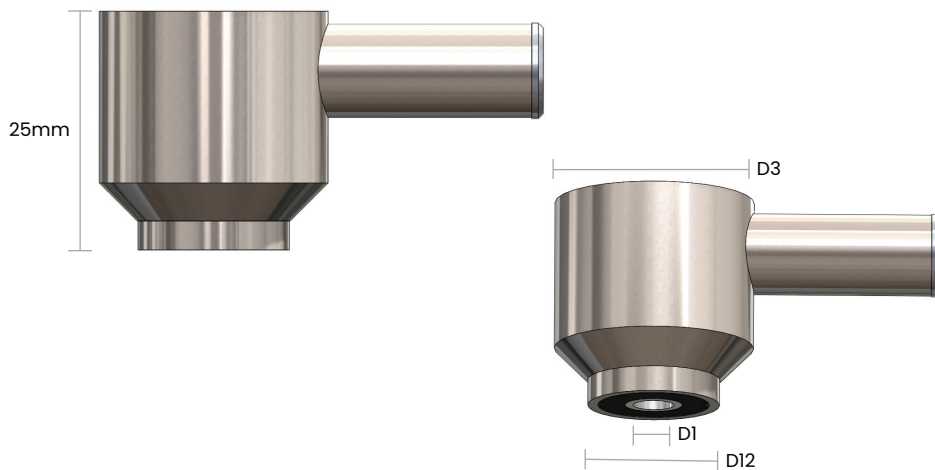

Spot face probes

Application

Detection of sub-surface corrosion and other flaws. Excellent depth penetration, typically used in the inspection of aircraft fasteners.

Features

These lower frequency absolute - reflection probes employ a magnetic core for focused penetration through several layers of test material. Compatible with most phase plane instruments. These probes are supplied with a 4 way Lemo connector.

Low frequency reflection probes				
Frequency	D	L	Part number	
1kHz-100kHz	7	48	632-483-007	(700P07A)
300Hz-100kHz	11	45	632-483-011	(700P11A)
300Hz-100kHz	16	45	632-483-016	(700P16A)
80Hz-60kHz	24	58	632-483-024	(700P24A)
80Hz-30kHz	32	38	632-483-032	(700P32A)

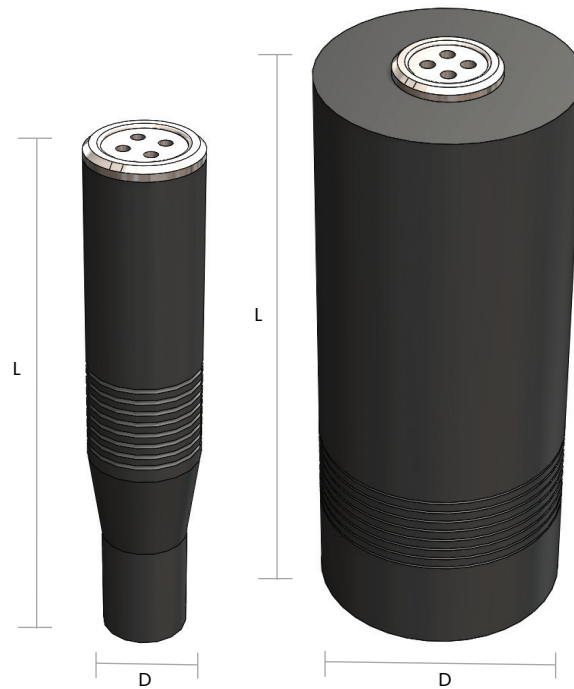
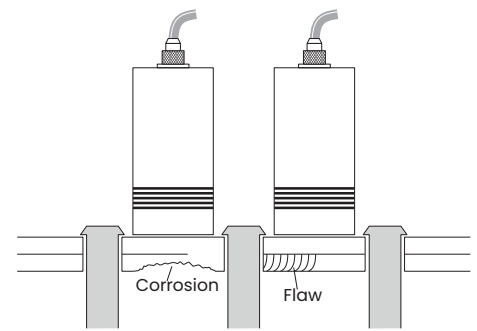

inches	1/32	.004	1/16	0.08	1/8	1/5	1/4	3/8	0.4	1/2	5/8	3/4	1	1 1/2	2	3	4	5	6	7	8	9	10	11	12
mm	0.8	1	1.6	2	3.2	5	6.4	9.5	10	12.7	15.9	19	25.4	38	51	76	102	127	152	178	203	229	254	279	305

Aircraft fastener inspection 2

Sliding probes, dual element

Application

To slide along rows of fasteners on aircraft wing skins and other similar structures. Detect cracks and corrosion on or near the surface around fasteners and, at low frequencies, in deeper layers under the surface.

Features

Reflection probes contain a transmitter element and a receiver element housed inside the block. The underside of the block is, in some cases, relieved to slide over raised fasteners. These probes are supplied with 4 way Lemo connectors and are used with standard reflection probe cables.

Sliding block probes						
Frequency	L	H	D	Part number		Notes
400Hz-50kHz	52	34	20	632-481-500	(851P001)	4 pin Lemo connector
1kHz-100kHz	52	34	20	379-010-300		4 pin Lemo connector
100Hz-500kHz	43*	20	26	632-481-501	(851P002)	Dual microdot connectors

Note: (*) indicates adjustable length as lens provided in 1.5mm/2.5mm and 3.5mm thicknesses

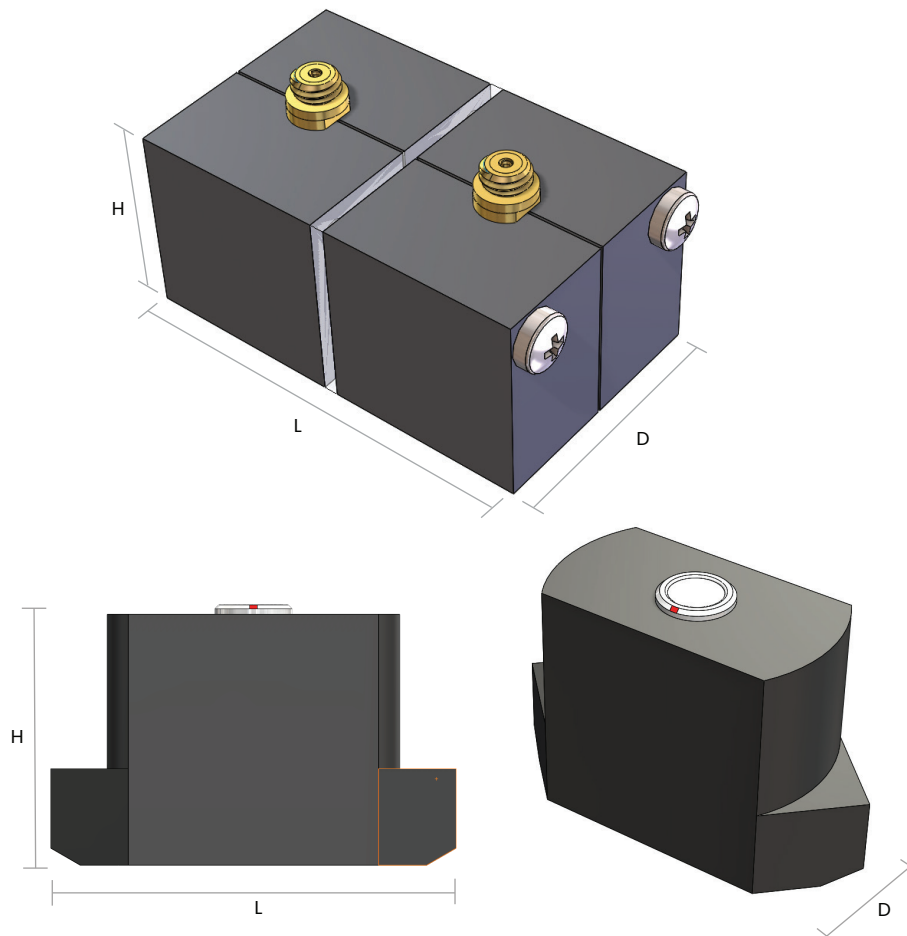

Bolt hole inspection

Application

Inspection of the bore of bolt holes for cracks and corrosion. Hand operated.

Features

All probes have a Delrin tip. Flexible probes allow inspection when access is not directly in line with the hole. Microdot connector.

Bolt hole probes 3.2mm – 4.3mm

Numbering system				
624	-	01	X-	XXX

D - head diameter
(see XXX value in tables)

Frequency range	
4	20 - 200kHz
5	50 - 500kHz
7	350kHz- 3MHz

mm	-XXX	20-200kHz	50-500kHz	350kHz-3MHz
3.2	008	(501P08)	(503P08)	(504P08)
3.6	009	(501P09)	(503P09)	(504P09)
3.9	010	(501P10)	(503P10)	(504P10)
4.3	011	(501P11)	(503P11)	(504P11)

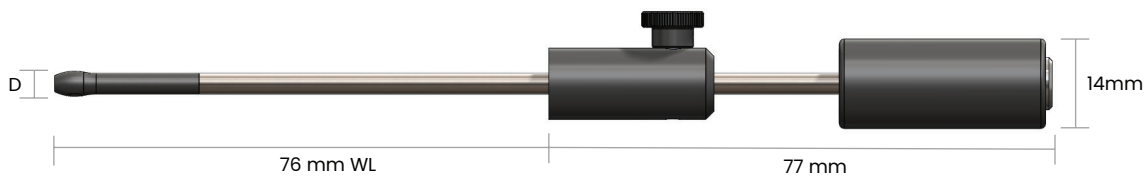

Rigid Bolt Hole Probes 4.5mm – 11.5 (with split)

Numbering system				
624	-	01	X-	XXX

D - head diameter
(see XXX value in tables)

Frequency range	
4	20 - 200kHz
5	50 - 500kHz
7	350kHz- 3MHz

mm	-XXX	20-200kHz	50-500kHz	350kHz-3MHz
4.5-5.5	012	(501P12)	(503P12)	(504P12)
5.5-6.5	014	(501P14)	(503P14)	(504P14)
6.0-7.0	016	(501P16)	(503P16)	(504P16)
7.0-8.0	018	(501P18)	(503P18)	(504P18)
7.5-8.5	020	(501P20)	(503P20)	(504P20)
8.5-10.0	022	(501P22)	(503P22)	(504P22)
9.5-11.0	024	(501P24)	(503P24)	(504P24)
10.0-11.5	026	(501P26)	(503P26)	(504P26)

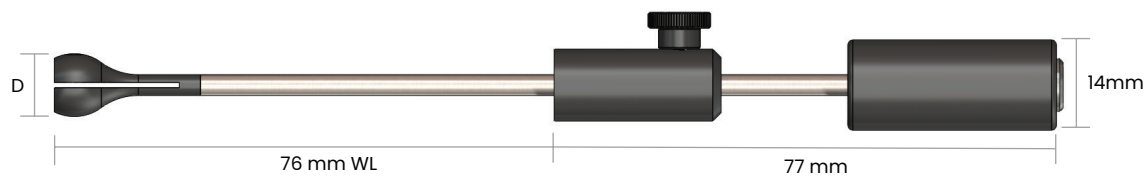

Rigid bolt hole probes

Application

Hand operated probe used for the inspection of bores holes for cracks and corrosion

Features

All probes have a Delrin tip and fitted with a Microdot connector. Between diameter ranges of 4.5 to 11.5 heads are provided with a split allowing for inspection of a range of hole diameters.

3.2mm - 4.3mm diameter heads

Numbering system				
624	-	01	X-	XXX

D - head diameter
(see XXX value in tables)

Frequency range	
4	20 - 200kHz
5	50 - 500kHz
7	350kHz- 3MHz

mm	-XXX	20-200kHz	50-500kHz	350kHz-3MHz
3.2	008	(501P08)	(503P08)	(504P08)
3.6	009	(501P09)	(503P09)	(504P09)
3.9	010	(501P10)	(503P10)	(504P10)
4.3	011	(501P11)	(503P11)	(504P11)

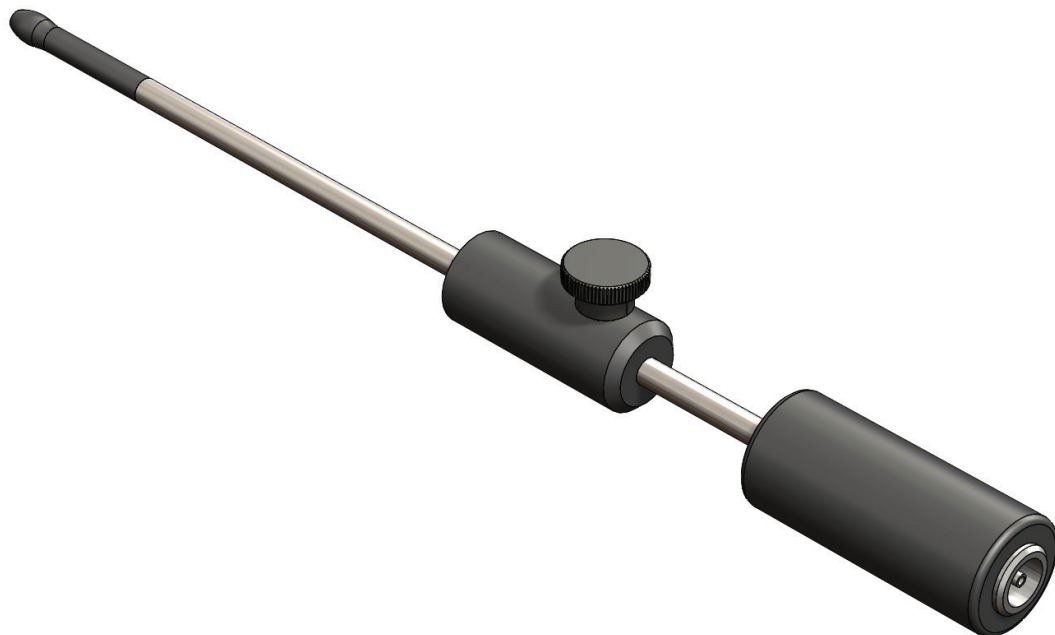
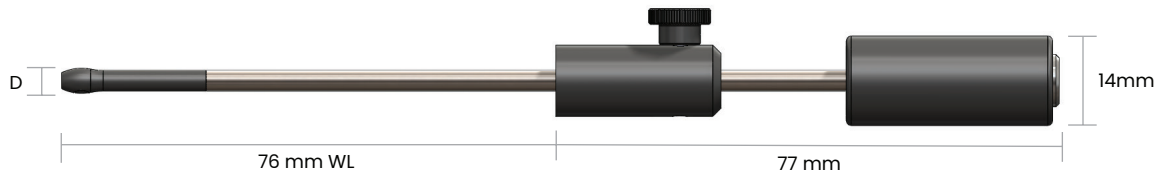

Rigid bolt hole probes

4.5mm - 11.5mm diameter heads

Numbering system				
624	-	01	X-	XXX

D - head diameter
(see XXX value in tables)

Frequency range	
4	20 - 200kHz
5	50 - 500kHz
7	350kHz- 3MHz

mm	-XXX	20-200kHz	50-500kHz	350kHz-3MHz
4.5-5.5	012	(501P12)	(503P12)	(504P12)
5.5-6.5	014	(501P14)	(503P14)	(504P14)
6.0-7.0	016	(501P16)	(503P16)	(504P16)
7.0-8.0	018	(501P18)	(503P18)	(504P18)
7.5-8.5	020	(501P20)	(503P20)	(504P20)
8.5-10.0	022	(501P22)	(503P22)	(504P22)
9.5-11.0	024	(501P24)	(503P24)	(504P24)
10.0-11.5	026	(501P26)	(503P26)	(504P26)

Note:

1. Head of probe is split allowing for a range of hole diameters to be inspected

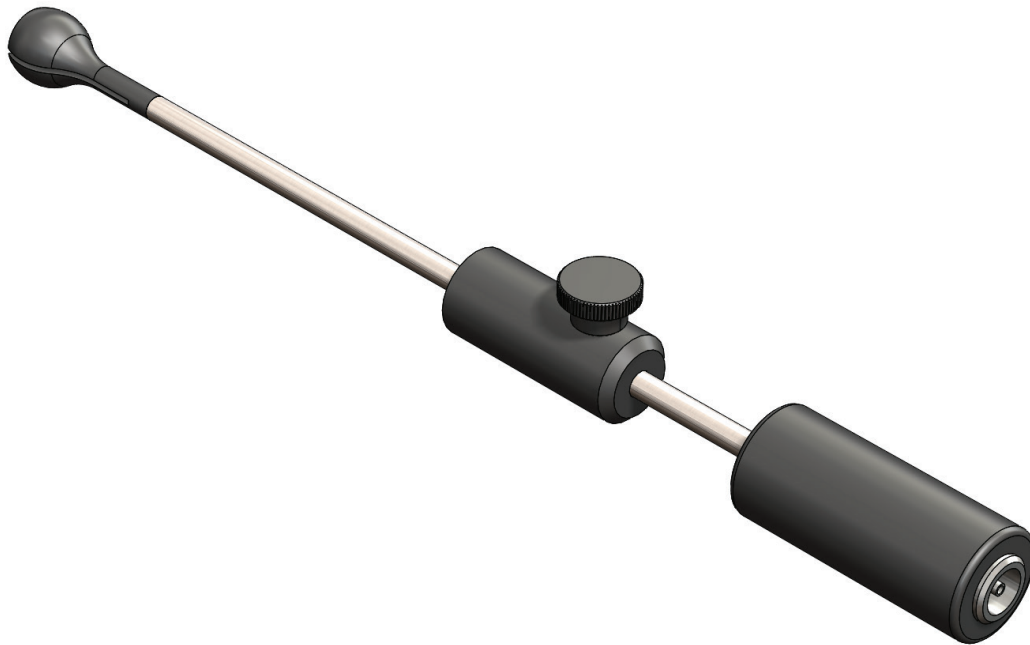
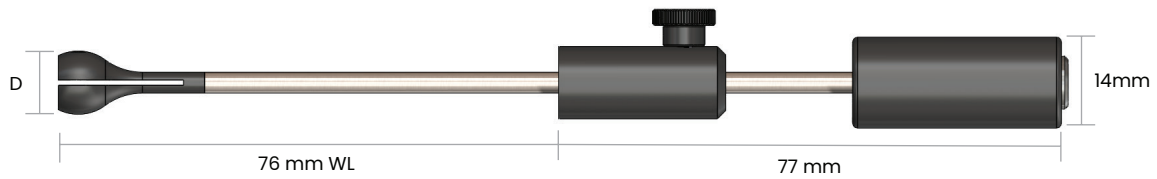

Rigid bolt hole probes

11mm - 25mm diameter heads

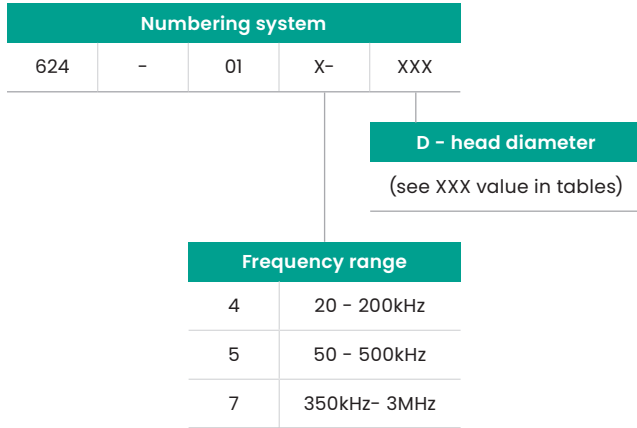

Note:
 1. While split present in the thickness of the probe head restricts the ability to inspect a range of diameters.

mm	-XXX	20-200kHz	50-500kHz	350kHz-3MHz
11	028	(501P28)	(503P28)	(504P28)
11.5	030	(501P30)	(503P30)	(504P30)
12.5	032	(501P32)	(503P32)	(504P32)
13	034	(501P34)	(503P34)	(504P34)
14	036	(501P36)	(503P36)	(504P36)
15	038	(501P38)	(503P38)	(504P38)
15.5	040	(501P40)	(503P40)	(504P40)
16.5	042	(501P42)	(503P42)	(504P42)
17	044	(501P44)	(503P44)	(504P44)
18	046	(501P46)	(503P46)	(504P46)
19	048	(501P48)	(503P48)	(504P48)
19.5	050	(501P50)	(503P50)	(504P50)
20.5	052	(501P52)	(503P52)	(504P52)
21	054	(501P54)	(503P54)	(504P54)
22	056	(501P56)	(503P56)	(504P56)
23	058	(501P58)	(503P58)	(504P58)
23.5	060	(501P60)	(503P60)	(504P60)
24.5	062	(501P62)	(503P62)	(504P62)
25	064	(501P64)	(503P64)	(504P64)

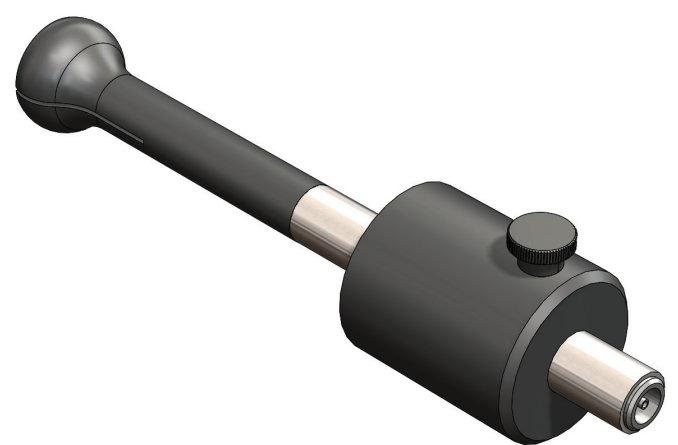
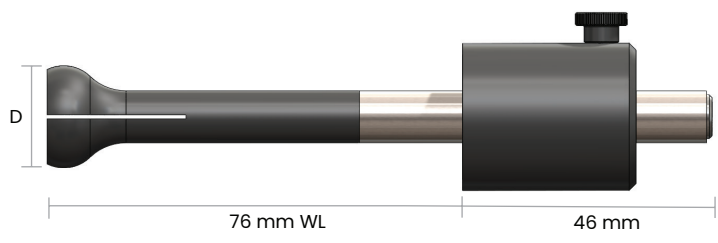

Rotational probes

Application

Inspection of the inner surface of bore holes, countersinks and counterbores. For use with the Waygate Technologies Minidrive and suitable eddy current unit. Frequency range 200kHz to 2MHz.

Features

Our rotational probes are a differential shielded configuration with a stainless steel base with either a Delrin or stainless steel shaft. These probes are built with a 4 pin Fischer connector

Numbering system					
62	X	-	XX	6-	XXX
			D - head diameter (see XXX value in tables)		
Head Material		Working length (WL)			
Delrin	0	54	Inch	1.4"	
Steel	1	55	Metric	35mm	
		56	Inch	2.6"	
		57	Metric	65mm	
		58	Inch	4"	
		59	Metric	100mm	
		60	Inch	2.0"	
		61	Metric	51mm	
		25	064	(501P64)	

Note:

1. Steel standard diameter increments = 1/64" or 0.1 mm.
2. Plastic head standard diameter increments = 1/64" or 0.1 mm for up to 5.0mm and then increasing by 0.5mm (split head configuration).
3. Inches and Metric units cannot be mixed.
4. (*) indicates plastic probe heads only available in solid configuration = no split.

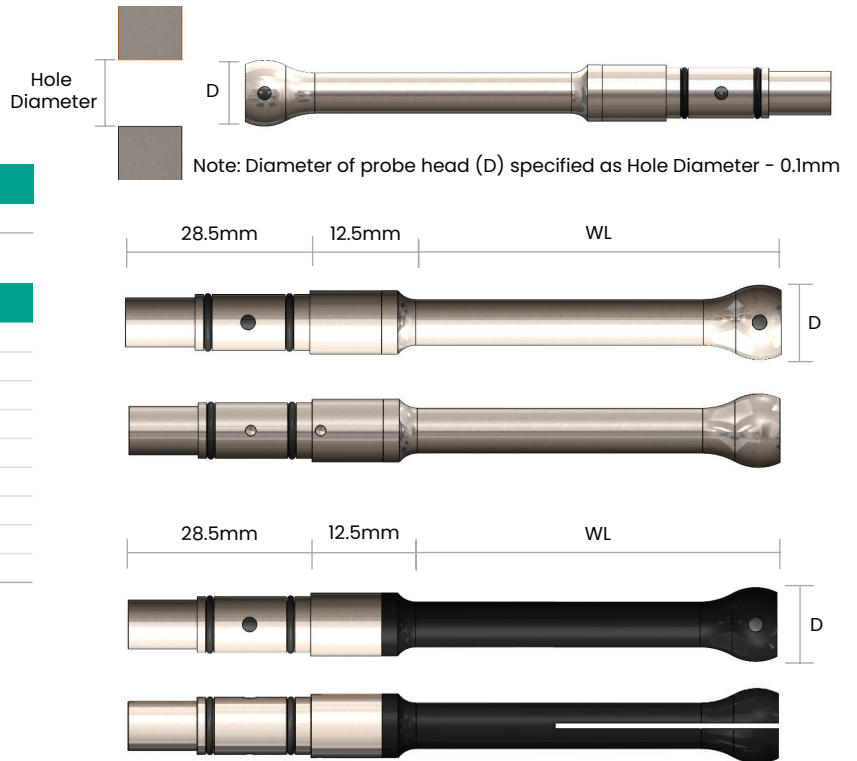

Imperial head diameter					
inches	-XXX	inches	-XXX	inches	-XXX
1/8"	(0.13)	008*	27/64"	(0.42)	027
9/64"	(0.14)	009*	7/16"	(0.44)	028
5/32"	(0.16)	010*	29/64"	(0.45)	029
11/64"	(0.17)	011*	15/32"	(0.47)	030
3/16"	(0.19)	012	31/64"	(0.48)	031
13/64"	(0.2)	013	1/2"	(0.5)	032
7/32"	(0.22)	014	33/64"	(0.52)	033
15/64"	(0.23)	015	17/32"	(0.53)	034
1/4"	(0.25)	016	35/64"	(0.55)	035
17/64"	(0.27)	017	9/16"	(0.56)	036
9/32"	(0.28)	018	37/64"	(0.58)	037
19/64"	(0.3)	019	19/32"	(0.59)	038
5/16"	(0.31)	020	39/64"	(0.61)	039
21/64"	(0.33)	021	5/8"	(0.63)	040
11/32"	(0.34)	022	41/64"	(0.64)	041
23/64"	(0.36)	023	21/32"	(0.66)	042
3/8"	(0.38)	024	43/64"	(0.67)	043
25/64"	(0.39)	025	11/16"	(0.69)	044
13/32"	(0.41)	026	45/64"	(0.7)	045

Metric head diameter													
mm	-XXX	mm	-XXX	mm	-XXX	mm	-XXX	mm	-XXX	mm	-XXX	mm	-XXX
3.5	035*	5.4	054	7.3	073	9.6	096	11.5	115	18.9	189	20.8	208
3.6	036*	5.5	055	7.4	074	9.7	097	11.6	116	19.0	190	20.9	209
3.7	037*	5.6	056	7.5	075	9.8	098	11.7	117	19.1	191	21.0	210
3.8	038*	5.7	057	7.6	076	9.9	099	11.8	118	19.2	192	21.1	211
3.9	039*	5.8	058	7.7	077	10.0	100	11.9	119	19.3	193	21.2	212
4.0	040*	5.9	059	7.8	078	10.1	101	12.0	120	19.4	194	21.3	213
4.1	041*	6.0	060	7.9	079	10.2	102	12.1	121	19.5	195	21.4	214
4.2	042*	6.1	061	8.0	080	10.3	103	12.2	122	19.6	196	21.5	215
4.3	043*	6.2	062	8.1	081	10.4	104	12.3	123	19.7	197	21.6	216
4.4	044*	6.3	063	8.2	082	10.5	105	12.4	124	19.8	198	21.7	217
4.5	045*	6.4	064	8.3	083	10.6	106	12.5	125	19.9	199	21.8	218
4.6	046*	6.5	065	8.4	084	10.7	107	12.6	126	20.0	200	21.9	219
4.7	047*	6.6	066	8.5	085	10.8	108	12.7	127	20.1	201	22.0	220
4.8	048*	6.7	067	9.0	090	10.9	109	12.8	128	20.2	202	22.1	221
4.9	049*	6.8	068	9.1	091	11.0	110	12.9	129	20.3	203	22.2	222
5.0	050*	6.9	069	9.2	092	11.1	111	18.5	185	20.4	204	22.3	223
5.1	051	7.0	070	9.3	093	11.2	112	18.6	186	20.5	205	22.4	224
5.2	052	7.1	071	9.4	094	11.3	113	18.7	187	20.6	206	22.5	225
5.3	053	7.2	072	9.5	095	11.4	114	18.8	188	20.7	207	22.6	226

Weld inspection

WeldScan

Application

WeldScan probes offer a cost-effective alternative to magnetic particle inspection (MPI) for in-service inspection of welded steel structures. Find cracks through paint and oil etc.

Features

Below outlines our range of 4P lemo weldscan probes. Waygate additionally offer other connector types in hardwired cabled versions on request.

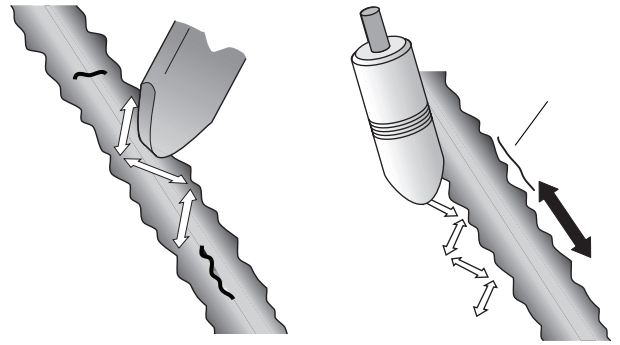

Scan pattern technique to detect surface or near surface cracks in the weld cap.

Scanning technique to detect surface or near surface cracks in the weld toe and heat affected zone of the parent metal.

Straight weldscan probes					
Frequency	Tip diameter (D)	L	Part number	Note	
450kHz-2.5MHz	6	65	632-267-008	Standard straight weldscan	
60kHz-1.2MHz	10	65	632-266-008	Standard straight weldscan	
60kHz-700kHz	16	65	632-265-009	Standard straight weldscan	
20kHz-200kHz	32	130	632-264-008	Standard straight weldscan	
60kHz-1.2MHz	10	65	632-266-011	Highwear ceramic tip straight weldscan	
60kHz-700kHz	16	65	632-265-011	Highwear ceramic tip straight weldscan	
60kHz-700kHz	16	65	632-265-018	Highwear SST tip straight weldscan	
60kHz-1.2MHz	10	65	632-266-009	High temperature straight weldscan	
60kHz-700kHz	16	65	632-265-008	High temperature straight weldscan	
60kHz-1.2MHz	10	105	632-266-508	Waterproof straight weldscan	
60kHz-700kHz	16	105	632-265-508	Waterproof straight weldscan	
20kHz-200kHz	32	130	632-264-508	Waterproof straight weldscan	

90° tipped weldscan probes						
Frequency	Tip diameter (D)	L	X	Part number	Note	
450kHz-2.5MHz	6	40	6	632-267-108	Standard inline 90° tipped weldscan	
60kHz-1.2MHz	10	40	6	632-266-108	Standard inline 90° tipped weldscan	
20kHz-200kHz	10	40	6	632-266-208	Standard 90° tipped weldscan	
60kHz-700kHz	16	65	6	632-265-108	Standard inline 90° tipped weldscan	
60kHz-700kHz	16	65	6	632-265-208	Standard 90° tipped weldscan	
20kHz-200kHz	32	130	20	632-264-108	Standard inline 90° tipped weldscan	
20kHz-200kHz	32	130	20	632-264-208	Standard 90° tipped weldscan	

Encircling probes

Application

Absolute encircling coils for the inspection of tube, bar and wire.
 Detection of surface breaking cracks and comparative material sorting.

Features

These probes are made up of a Delrin block housing with wear plates and a 6pin Jaeger connector. Coil configurations of absolute and differential are available.

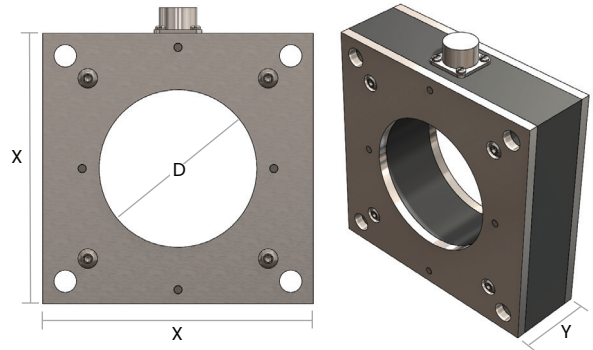

Numbering system					
630	-	CC	F	-	XXX

Coil configuration

13	Absolute
30	Differential

D - head diameter

(see XXX value in tables)

Frequency

1	500Hz - 5kHz
2	2.5kHz - 25kHz
3	7kHz - 60kHz
4	20kHz - 200kHz
5	50kHz - 500kHz
6	120kHz - 1MHz
7	350kHz - 3MHz
8	1MHz - 6MHz
9	3MHz - 10MHz

$$\text{Internal diameter} = \frac{\sqrt{(\text{OD of test piece})^2}}{0.85}$$

Note:

- For internal diameters up to 0.75" X=3.0" Y=1.1"
- For internal diameters greater than 0.751" X=6.0" Y=1.5"

Metric head diameter													
mm	-XXX	mm	-XXX	mm	-XXX	mm	-XXX	mm	-XXX	mm	-XXX	mm	-XXX
3.5	035*	5.4	054	7.3	073	9.6	096	11.5	115	18.9	189	20.8	208
3.6	036*	5.5	055	7.4	074	9.7	097	11.6	116	19.0	190	20.9	209
3.7	037*	5.6	056	7.5	075	9.8	098	11.7	117	19.1	191	21.0	210
3.8	038*	5.7	057	7.6	076	9.9	099	11.8	118	19.2	192	21.1	211
3.9	039*	5.8	058	7.7	077	10.0	100	11.9	119	19.3	193	21.2	212
4.0	040*	5.9	059	7.8	078	10.1	101	12.0	120	19.4	194	21.3	213
4.1	041*	6.0	060	7.9	079	10.2	102	12.1	121	19.5	195	21.4	214
4.2	042*	6.1	061	8.0	080	10.3	103	12.2	122	19.6	196	21.5	215
4.3	043*	6.2	062	8.1	081	10.4	104	12.3	123	19.7	197	21.6	216
4.4	044*	6.3	063	8.2	082	10.5	105	12.4	124	19.8	198	21.7	217
4.5	045*	6.4	064	8.3	083	10.6	106	12.5	125	19.9	199	21.8	218
4.6	046*	6.5	065	8.4	084	10.7	107	12.6	126	20.0	200	21.9	219
4.7	047*	6.6	066	8.5	085	10.8	108	12.7	127	20.1	201	22.0	220
4.8	048*	6.7	067	9.0	090	10.9	109	12.8	128	20.2	202	22.1	221
4.9	049*	6.8	068	9.1	091	11.0	110	12.9	129	20.3	203	22.2	222
5.0	050*	6.9	069	9.2	092	11.1	111	18.5	185	20.4	204	22.3	223
5.1	051	7.0	070	9.3	093	11.2	112	18.6	186	20.5	205	22.4	224
5.2	052	7.1	071	9.4	094	11.3	113	18.7	187	20.6	206	22.5	225
5.3	053	7.2	072	9.5	095	11.4	114	18.8	188	20.7	207	22.6	226
										20.8	208	22.7	227
										20.9	209	22.8	228
										21.0	210	22.9	229
										21.1	211	23.0	230
										21.2	212	23.1	231
										21.3	213	23.2	232
										21.4	214	23.3	233
										21.5	215	23.4	234
										21.6	216	23.5	235
										21.7	217	23.6	236
										21.8	218	23.7	237
										21.9	219	23.8	238
										22.0	220	23.9	239
										22.1	221	24.0	240
										22.2	222	24.1	241
										22.3	223	24.2	242
										22.4	224	24.3	243
										22.5	225	24.4	244
										22.6	226	24.5	245

Internal diameter																			
inches	-XXX	inches	-XXX	inches	-XXX	inches	-XXX	inches	-XXX	inches	-XXX	inches	-XXX	inches	-XXX	inches	-XXX	inches	-XXX
1/64"	001	5/16"	020	39/64"	039	29/32"	058	1-13/64"	077	1-1/2"	096	1-51/64"	115	2-3/32"	134	2-25/64"	153	2-11/16"	172
(0.016)		(0.313)		(0.609)		(0.906)		(1.203)		(1.5)		(1.797)		(2.094)		(2.391)		(2.688)	
1/32"	002	21/64"	021	5/8"	040	59/64"	059	1-7/32"	078	1-13/16"	097	1-13/16"	116	2-7/64"	135	2-13/32"	154	2-45/64"	173
(0.031)		(0.328)		(0.625)		(0.922)		(1.219)		(1.516)		(1.813)		(2.109)		(2.406)		(2.703)	
3/64"	003	11/32"	022	41/64"	041	15/16"	060	1-15/64"	079	1-17/32"	098	1-53/64"	117	2-1/8"	136	2-27/64"	155	2-23/32"	174
(0.047)		(0.344)		(0.641)		(0.938)		(1.234)		(1.531)		(1.828)		(2.125)		(2.422)		(2.719)	
1/16"	004	23/64"	023	21/32"	042	61/64"	061	1-1/4"	080	1-35/64"	099	1-27/32"	118	2-9/64"	137	2-7/16"	156	2-47/64"	175
(0.063)		(0.359)		(0.656)		(0.953)		(1.25)		(1.547)		(1.844)		(2.141)		(2.438)		(2.734)	
5/64"	005	3/8"	024	43/64"	043	31/32"	062	1-17/64"	081	1-9/16"	100	1-55/64"	119	2-5/32"	138	2-29/64"	157	2-3/4"	176
(0.078)		(0.375)		(0.672)		(0.969)		(1.266)		(1.563)		(1.859)		(2.156)		(2.453)		(2.75)	
3/32"	006	25/64"	025	11/16"	044	63/64"	063	1-9/32"	082	1-37/64"	101	1-7/8"	120	2-11/64"	139	2-15/32"	158	2-49/64"	177
(0.094)		(0.391)		(0.688)		(0.984)		(1.281)		(1.578)		(1.875)		(2.172)		(2.469)		(2.766)	
7/64"	007	13/32"	026	45/64"	045	64/64"	064	1-19/64"	083	1-19/32"	102	1-57/64"	121	2-3/16"	140	2-31/64"	159	2-25/32"	178
(0.109)		(0.406)		(0.703)		(1)		(1.297)		(1.594)		(1.891)		(2.188)		(2.484)		(2.781)	
1/8"	008*	27/64"	027	23/32"	046	1-1/64"	065	1-5/16"	084	1-39/64"	103	1-29/32"	122	2-13/64"	141	2-1/2"	160	2-51/64"	179
(0.125)		(0.422)		(0.719)		(1.016)		(1.313)		(1.609)		(1.906)		(2.203)		(2.5)		(2.797)	
9/64"	009*	7/16"	028	47/64"	047	1-1/32"	066	1-21/64"	085	1-5/8"	104	1-59/64"	123	2-7/32"	142	2-33/64"	161	2-13/16"	180
(0.141)		(0.438)		(0.734)		(1.031)		(1.344)		(1.625)		(1.922)		(2.219)		(2.516)		(2.813)	
5/32"	010*	29/64"	029	3/4"	048	1-3/64"	067	1-11/32"	086	1-41/64"	105	1-15/16"	124	2-15/64"	143	2-17/32"	162	2-53/64"	181
(0.156)		(0.453)		(0.75)		(1.047)		(1.328)		(1.641)		(1.938)		(2.234)		(2.531)		(2.828)	
11/64"	011*	15/32"	030	49/64"	049	1-1/16"	068	1-23/64"	087	1-21/32"	106	1-61/64"	125	2-1/4"	144	2-35/64"	163	2-27/32"	182
(0.172)		(0.469)		(0.766)		(1.063)		(1.359)		(1.656)		(1.953)		(2.25)		(2.547)		(2.844)	
3/16"	012	31/64"	031	25/32"	050	1-5/64"	069	1-3/8"	088	1-43/64"	107	1-31/32"	126	2-17/64"	145	2-9/16"	164	2-55/64"	183
(0.188)		(0.484)		(0.781)		(1.078)		(1.375)		(1.672)		(1.969)		(2.266)		(2.563)		(2.859)	
13/64"	013	1/2"	032	51/64"	051	1-3/32"	070	1-25/64"	089	1-11/16"	108	1-63/64"	127	2-9/32"	146	2-37/64"	165	2-7/8"	184
(0.203)		(0.5)		(0.797)		(1.094)		(1.391)		(1.688)		(1.984)		(2.281)		(2.578)		(2.875)	
7/32"	014	33/64"	033	13/16"	052	1-7/64"	071	1-13/32"	090	1-45/64"	109	2-0"	128	2-19/64"	147	2-19/32"	166	2-57/64"	185
(0.219)		(0.516)		(0.813)		(1.109)		(1.406)		(1.703)		(2)		(2.297)		(2.594)		(2.891)	
15/64"	015	17/32"	034	53/64"	053	1-1/8"	072	1-27/64"	091	1-23/32"	110	2-1/64"	129	2-5/16"	148	2-39/64"	167	2-29/32"	186
(0.234)		(0.531)		(0.828)		(1.125)		(1.422)		(1.719)		(2.016)		(2.313)		(2.609)		(2.906)	
1/4"	016	35/64"	035	27/32"	054	1-9/64"	073	1-7/16"	092	1-47/64"	111	2-1/32"	130	2-21/64"	149	2-5/8"	168	2-59/64"	187
(0.25)		(0.547)		(0.844)		(1.141)		(1.438)		(1.734)		(2.031)		(2.328)		(2.625)		(2.922)	
17/64"	017	9/16"	036	55/64"	055	1-5/32"	074	1-29/64"	093	1-3/4"	112	2-3/64"	131	2-11/32"	150	2-41/64"	169	2-15/16"	188
(0.266)		(0.563)		(0.859)		(1.156)		(1.453)		(1.75)		(2.047)		(2.344)		(2.641)		(2.938)	
9/32"	018	37/64"	037	7/8"	056	1-11/64"	075	1-15/32"	094	1-49/64"	113	2-1/16"	132	2-23/64"	151	2-21/32"	170	2-61/64"	189
(0.281)		(0.578)		(0.875)		(1.172)		(1.469)		(1.766)		(2.063)		(2.359)		(2.656)		(2.953)	
19/64"	019	19/32"	038	57/64"	057	1-3/16"	076	1-31/64"	095	1-25/32"	114	2-5/64"	133	2-3/8"	152	2-43/64"	171	2-31/32"	190
(0.297)		(0.594)		(0.891)		(1.188)		(1.484)		(1.781)		(2.078)		(2.375)		(2.672)		(2.969)	

Industrial applications 1

Flat surface probes

Application

Metal sorting and general surface crack inspection.

Features

These probes have a wide scanning area and are designed for use on relatively flat, smooth surfaces. Their stainless steel body provides semi-shielding while an integral load reduces thermal effect. Supplied with a 4 pin lemo connector these probes utilise bridge cables.

Flat surface probes			
Frequency	Tip diameter (D)	Part number	
1.5kHz - 10kHz	0.5"	632-267-008	(720P1F50)
5kHz - 40kHz	0.5"	632-266-008	(720P1F40)
50kHz - 400kHz	0.5"	632-265-009	(720P1F30)
250kHz - 2MHz	0.5"	632-264-008	(720P1F20)
500kHz - 4MHz	0.5"	632-266-011	(720P1F10)
1.5kHz - 10kHz	0.75"	632-265-011	(720P2F50)
5kHz - 40kHz	0.75"	632-265-018	(720P2F40)
50kHz - 400kHz	0.75"	632-266-009	(720P2F30)
250kHz - 2MHz	0.75"	632-265-008	(720P2F20)
500kHz - 4MHz	0.75"	632-266-508	(720P2F10)

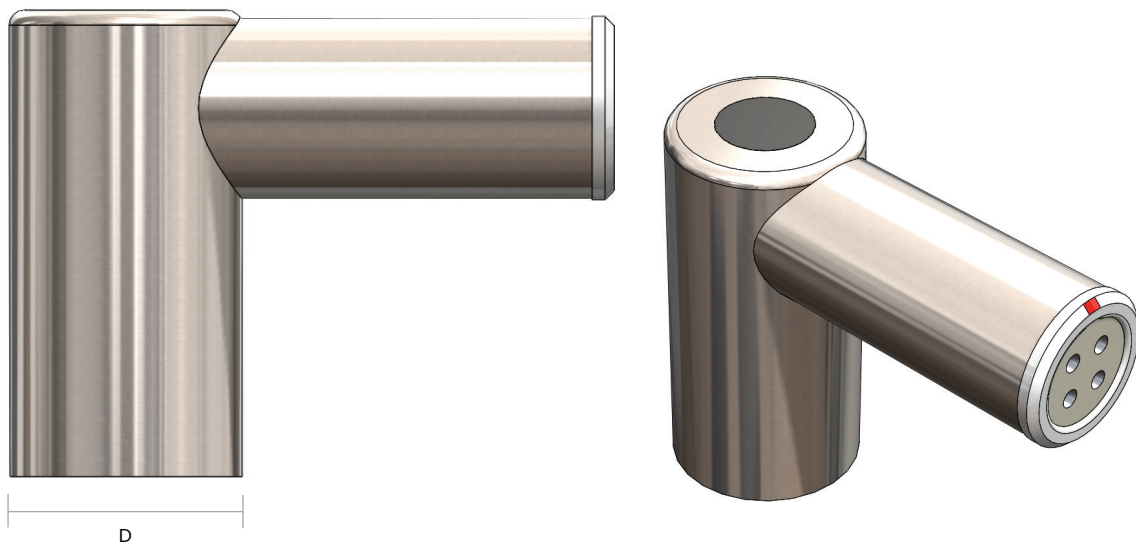

inches	1/32	.004	1/16	0.08	1/8	1/5	1/4	3/8	0.4	1/2	5/8	3/4	1	1 1/2	2	3	4	5	6	7	8	9	10	11	12
mm	0.8	1	1.6	2	3.2	5	6.4	9.5	10	12.7	15.9	19	25.4	38	51	76	102	127	152	178	203	229	254	279	305

Industrial applications 2

Static differential scanning probes

Application

Inspection of rotating test pieces such as bearings, housings, steering components, pins, bushes, automotive valves, bars and tubes. These probes are supplied with a 4 pin Lemo connector.

Differential shielded pencil probes

Frequency	Tip diameter (D)	Part number		Note
400kHz-3MHz	4	379-004-360	(5P495)	Straight flat tip
400kHz-3MHz	5	379-004-370	(5P469)	Straight flat tip
400kHz-3MHz	5	379-004-910	(5P411)	Straight flat tip ungrounded
120kHz-1MHz	5	379-012-730	(5P409)	Straight flat tip grounded
120kHz-1MHz	6	379-006-380	(5P436)	90° flat tip

Reflection unshielded pencil probes

Frequency	Tip diameter (D)	Part number		Note
100kHz-3MHz	6	379-011-950	(5P538)	Straight flat tip
200kHz-3MHz	2.5	379-012-140	(5P501)	Straight pointed tip
200kHz-3MHz	2.5	379-013-150	(5P504)	90° pointed tip

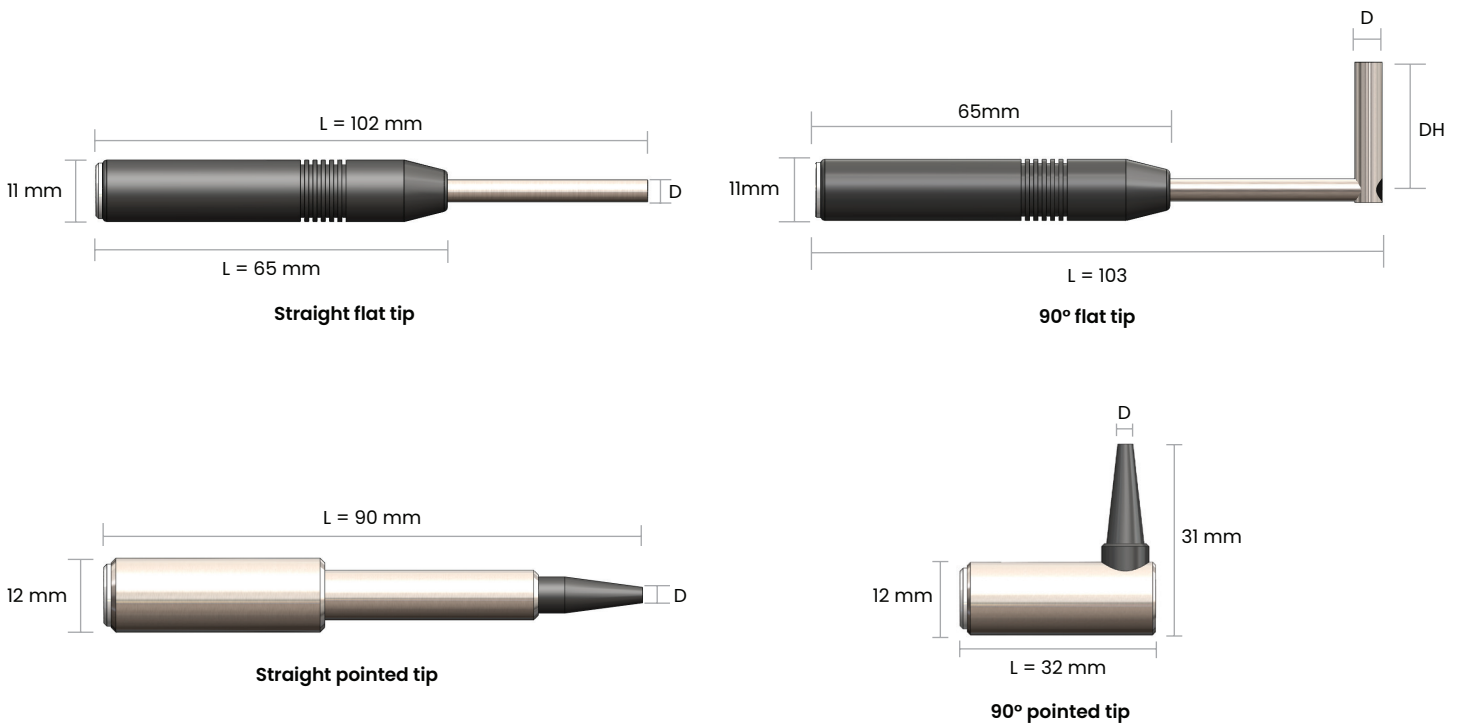

Eddy current kits

Eddy current kits		
Part number		Description
640-025-005		Eddy current rotary probe demo kt
640-030-040	(40A100-M)	Mini drive - rotating EC probe drive unit
620-546-016	(619P016F035)	Rotary probe, $\phi 1/4$ " split Delrin head, 200kHz-2MHz, 1.4" WL
621-546-016	(615P016F035)	Rotary probe, $\phi 1/4$ " solid SST head, 200kHz-2MHz, 1.4" WL
640-025-002	(33AT016V1)	Rotary probe reference block for $\phi 1/4$ " hole
640-010-048	(33A103U)	Mini drive cable 8 ft (2,4 m) length for Mentor EM
110-020-156		Teflon tape .75" width
640-025-014		EC rotary probe starter kit
640-030-040	(40A100-M)	Mini drive - rotating EC probe drive unit
640-010-048	(33A103U)	Mini drive cable 8 ft (2,4 m) length for Mentor EM
110-020-156		Teflon tape .75" width
640-025-004		EC surface probe demo kit
610-034-002	(104P4)	Eddy current straight pencil probe with $\phi 0.189$ " tip, 4.5"L, 20-200kHz
610-037-002	(106P4)	Eddy current straight pencil probe with $\phi 0.125$ " tip, 4.5"L, 350kHz-3MHz
610-074-008	(308P24)	Eddy current 90° pencil probe with a 0.25" drop and $\phi 0.189$ " tip, 4.5"L, 20-200kHz
610-077-002	(310P14)	Eddy current 90° pencil probe with a 0.25" drop and $\phi 0.125$ " tip, 4.5"L, 350kHz-3MHz
610-054-076	(204P4)	Eddy current 45° cranked pencil probe with a $\phi 0.189$ " tip, 4.5"L, 20-200kHz
610-057-076	(206P4)	Eddy current 45° cranked pencil probe with a $\phi 0.125$ " tip, 4.5"L, 350kHz-3MHz
610-094-111	(312P24)	Eddy current 15° cranked and 90° min drop pencil probe with a $\phi 0.189$ " tip, 4.5"L, 20-200kHz
610-097-111	(314P24)	Eddy current 15° cranked and 90° min drop pencil probe with a $\phi 0.125$ " tip, 4.5"L, 350kHz-3MHz
610-014-000	(120P1)	Eddy current absolute unshielded straight pencil probe, 20-200kHz
610-017-000	(122P1)	Eddy current absolute unshielded straight pencil probe, 350kHz-3MHz
632-483-011	(700P11A)	Eddy current low frequency surface reflection probe 300Hz-100kHz
632-483-024	(700P24A)	Eddy current low frequency surface reflection probe 80hZ-60kHz
118-140-012		Cable microdot to BNC, 6ft
640-015-120	(40A002A)	Adapter 12P Lemo to BNC
640-050-001	(29A028)	3 notch test block 4340 steel
640-050-002	(29A029)	3 notch test block 7075-T6 aluminium
640-050-003	(29A032)	3 notch test block titanium
640-050-004	(29A049)	3 notch test block 304 SST
074-140-024		Cable 12P Lemo to 4P Lemo, 5 ft (1,5 m)
110-020-156		Teflon tape .75" width

Eddy current kits

Eddy current kits		
Part number		Description
640-025-013		
EC weld expert kt		
632-266-008		Eddy current weldscan probe with a straight $\varnothing 3/8$ " tip, 60kHz-1.2MHz
632-265-009		Eddy current weldscan probe with a straight $\varnothing 5/8$ " tip, 60kHz-700kHz
632-266-108		Eddy current weldscan probe with a 90°, 0.25" inline drop and $\varnothing 3/8$ " tip, 60kHz-1.2MHz
632-266-208		Eddy current weldscan probe with a 90°, 0.25" drop and $\varnothing 3/8$ " tip, 20-200kHz
632-265-108		Eddy current weldscan probe with a 90°, 0.25" inline drop and $\varnothing 5/8$ " tip, 60kHz-700kHz
632-265-208		Eddy current weldscan probe with a 90°, 0.25" drop and $\varnothing 5/8$ " tip, 60kHz-700kHz
632-134-000	(130P3)	Eddy current broadband unshielded probe 35kHz-250kHz
640-050-000	(31A008)	3 notch test block 4340 steel with shims
640-010-304		Cable 12P Lemo to BNC, 6 ft (1,8 m)
074-140-022		Cable 12P Lemo to 4P Lemo, 5ft (1,5 m)
110-020-156		Teflon tape .75" width
640-025-012		
EC weld starter kit		
632-266-008		Eddy current weldscan probe with a straight $\varnothing 3/8$ " tip, 60kHz-1.2MHz
632-265-009		Eddy current weldscan probe with a straight $\varnothing 5/8$ " tip, 60kHz-700kHz
632-134-000	(130P3)	Eddy current broadband unshielded probe 35kHz-250kHz
640-010-304		Cable 12P Lemo to BNC, 6ft (1,8 m)
640-050-000	(31A008)	3 notch weldscan test block 4340 steel
074-140-022		Cable 12P Lemo to 4P Lemo, 5ft (1,5 m)
110-020-156		Teflon tape .75" width
640-025-003		
EC weldscan demo kit w/case		
632-266-008		Eddy current weldscan probe with a straight $\varnothing 3/8$ " tip, 60kHz-1.2MHz
632-265-009		Eddy current weldscan probe with a straight $\varnothing 5/8$ " tip, 60kHz-700kHz
632-134-000	(130P3)	Eddy current broadband unshielded probe 35kHz-250kHz
640-010-304		Cable 12P Lemo to BNC, 6ft (1,8 m)
074-140-022		Cable 12P Lemo to 4P Lemo, 5ft (1,5 m)
640-050-000	(31A008)	3 notch weldscan test block 4340 steel
640-025-003		Weldscan demonstration scanning block
110-020-156		Teflon tape .75" width

Cables

Mentor instrument cables (Lemo 12P connector)					
Part number	Cable type	Probe connector	Cable length		Suitable probe types
			(ft)	(meter)	
640-010-195	Abs/bridge/reflection	Lemo 6Pm	12	3.7	Abs/bridge/reflection
640-010-301	Absolute	Microdot	6	1.8	Absolute probes
640-010-304	Absolute	BNC	6	1.8	Absolute probes
074-140-022	Bridge	Lemo 4Pm	5	1.5	Bridge probes
074-140-023	Bridge	Lemo 4Pm	12	3.7	Bridge probes
074-140-025	Bridge	Dual MD	3	3.7	Beadseat probes
640-010-087	Bridge	Dual MD	8	2.4	Beadseat probes
640-010-093	Bridge	Lemo Triax	6	1.8	Bridge probes
640-010-114	Bridge	Lemo 4Pm	6	1.8	Bridge probes
640-010-191	Bridge	Lemo 4Pm	7	2.1	Bridge probes
640-010-297	Bridge	Fisher 4P	6	1.8	Bridge probes
640-010-170	Bridge	Lemo 4Pm	25	7.6	Bridge probes
640-010-196	Bridge	Lemo 4Pm	8	2.4	Bridge probes
640-010-014	Bridge/reflection	Jaeger 6Pf	6	1.8	Bridge encircling probes
640-010-184	Bridge/reflection	Jaeger 6Pf	12	3.7	Bridge/reflection
074-140-021	Reflection	Lemo 4Pm	12	3.7	Reflection probes
074-140-024	Reflection	Lemo 4Pm	5	1.5	Reflection probes
640-010-153	Reflection	Lemo Triax	6	1.8	Reflection probes
640-010-180	Reflection	Dual MD	6	1.8	Reflection probes
640-010-194	Reflection	Jaeger 6Pf	12	3.7	Reflection
640-010-072	Reflection	Lemo 4Pm	40	12.2	Reflection probes
640-010-075	Reflection	90° Lemo 4P	8	2.4	Reflection probes
640-010-143	Reflection	Lemo 4Pm	15	4.6	Reflection probes
640-010-291	Reverse reflection	Fisher 4P	6	1.8	Reflection probes
640-010-048	Rotary drive	Lemo 12P	8	2.4	Minidrive cable

Conductivity probe cables						
Part number	Instrument	Instrument connector	Probe connector	Cable length		Suitable probe types
				(ft)	(meter)	
640-010-179	Autosigma	Lemo 5P	Lemo 5P	10	3	Conductivity
640-010-010	Autosigma	Lemo 5P	Lemo 5P	4	1.2	Conductivity
640-010-315	Mentor EM	Lemo 6P	Lemo 6P	6	1.8	Conductivity
640-010-079	Phasec/Vector	Lemo 12P	Lemo 5P	6	1.8	Conductivity

Adapters and test blocks

Adapters						
Part number	Instrument	Instrument connector	Probe connector	Cable length		Suitable probe types
				(ft)	(meter)	
074-140-006	Generic	BNC	BNC	5	1.5	-
640-015-001	Generic	Lemo 12P	2X BNC	2	0.6	Abs/bridge probes
640-015-023	Waygate/GE/Hocking	Lemo 12P	Jaeger 6Pm	1	0.3	Abs/bridge/reflection probes
640-015-047	Waygate/GE/Hocking	Lemo 12P	Lemo 7Pf	1	0.3	Abs/bridge/reflection probes
640-015-120	GE/Hocking	Lemo 12P	BNC	-	-	Absolute probes
640-015-104	GE/Hocking	Lemo 12P	Lemo 00f	0.5	0.15	Absolute probes
640-015-005	Zetec	Lemo 12P	Amphenol 4Pf	1	0.3	Bridge probes
640-015-052	GE/Hocking	Lemo 12P	Lemo 16P	1	0.3	Bridge/reflection probes
640-015-057	Nortec	Lemo 12P	Lemo 16P	1	0.3	Bridge/reflection probes
640-015-043	Nortec	4PF	4PL	-	-	Nortec rotary probes
640-015-006	Zetec	Lemo 12P	Amphenol 4Pf	1	0.3	Reflection probes
640-015-007	Nortec	Lemo 12P	Burndy 8P	1	0.3	Reflection probes

Test blocks				
Part number		Description	Notch size (inches)	LxWxD (inches)
640-050-000	(31A008)	3 notch weldscan test block 4340 steel with shims	.02/.04/.08	3.5X1X0.25
640-050-001	(29A028)	3 notch test block 4340 steel	.008/.02/.04	3X1X.25
640-050-002	(29A029)	3 notch test block 7075-T6 aluminium	.008/.02/.04	3X1X0.25
640-050-003	(29A032)	3 notch test block titanium	.008/.02/.04	3X1X0.25
640-050-004	(29A049)	3 notch test block 304 SST	.008/.02/.04	3X1X0.25
640-050-005		3 notch test block 4340 steel	.012/.02/.04	6X2X0.4
640-050-006		3 notch test block 7075-T6 aluminium	.012/.02/.04	6X2X0.4
640-050-007	(29A029SH)	3 notch test block 7075-T6,29A029SH with shims	.008/.02/.04	3.5X1X0.25
640-050-008		3 notch test block aluminium 2024-T3	.008/.02/.04	3X1X.025
640-050-009	(29A120)	3 notch test block magnesium	.008/.02/.04	3X1X.0.25

